

BATHROOM ACCESSORIES **GW05 46 04 02 "CRETA SERIES" double paper holder**



Product description

Double paper holder.
Material: AISI 304 stainless steel
Finish: Chrome plated
Creta Series

Technical specifications:

"Creta Series" paper holder. The product consists of a wall mount, a wall plate covering the wall mount and a paper holder rod. The rod has a "T" shape and it's made of AISI 304 stainless steel. The wall plate is made of AISI 304 stainless steel and has a diameter of 64,5mm. The wall mount, made of steel, has two holes so it can be fixed to the wall by means of screws. The assembled set has a chrome plate finishing that provides it an appropriate resistance against corrosion. The product is anchored by means of 2 nylon wall plugs and 2 screws. The overall dimensions of the product are 64,5 x 181 x 87,5 mm. The bathroom accessory model is GW05 46 04 02, manufactured by GENWEC WASHROOM S.L. - Av. Joan Carles I, 46-48 08908 L'Hospitalet de Llobregat.

Technical characteristics

Product specifications

- Rod made of AISI 304 stainless steel.
- Wall plate made of AISI 304 stainless-steel with a 64,5 mm diameter.
- The metal parts have a chrome plate finishing that provides them an appropriate resistance against corrosion.

Packaging specifications

- Type of individual package: Individual cardboard box and bubble wrap.

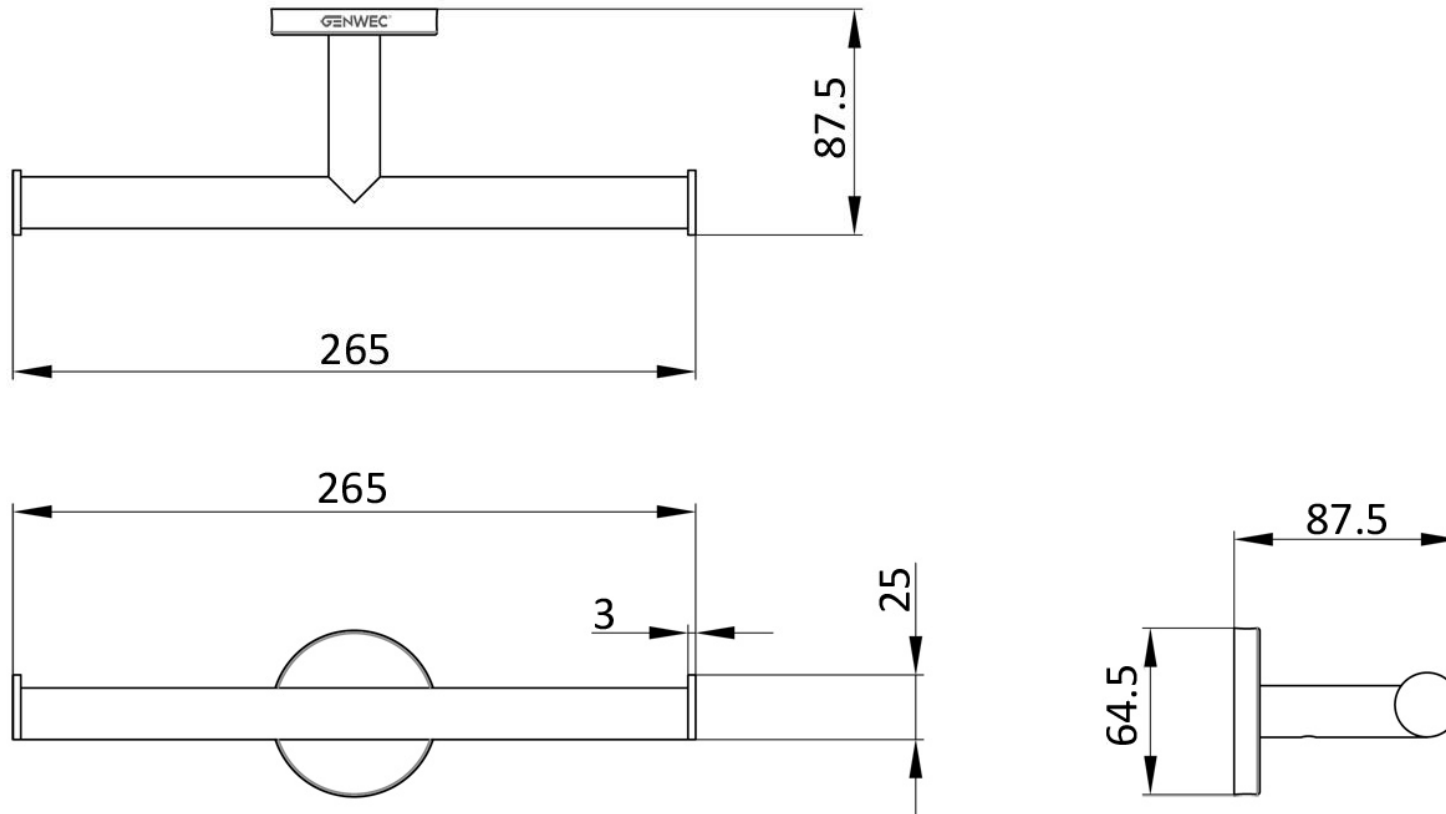

Cleaning: A cotton cloth slightly dampened in a soapy solution is recommended. Then dry off.